



LUMINATOR
TECHNOLOGY GROUP

PaCIM Software

Interface with on board
application

Dynamic Route Fetch with PaCIM

Purpose:

Getting the updated planned journey data from central system of particular route for the vehicle.

Advantage:

Driver can get the updated information of the route
Example: change in the route, disturbance, etc.

Passenger will receive actual route information on on-board units

Operator can easily interchange the vehicle for various routes.

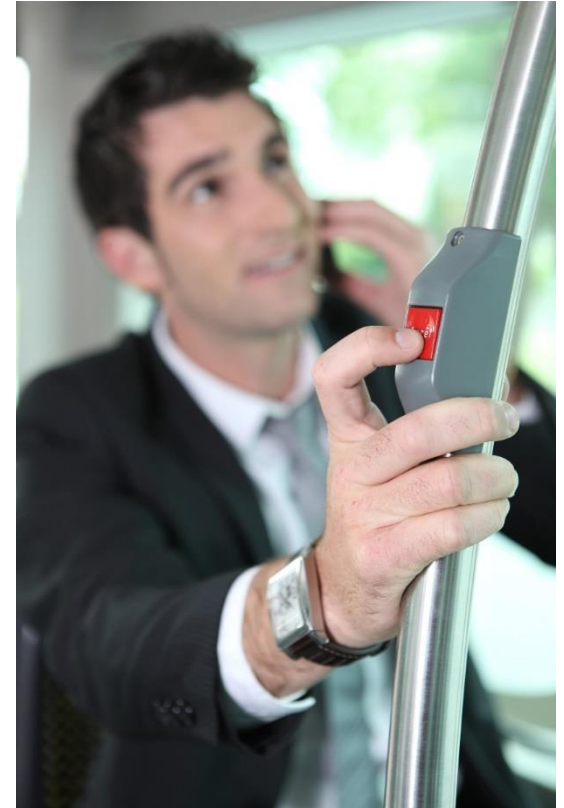

Dynamic Route Fetch with PaCIM

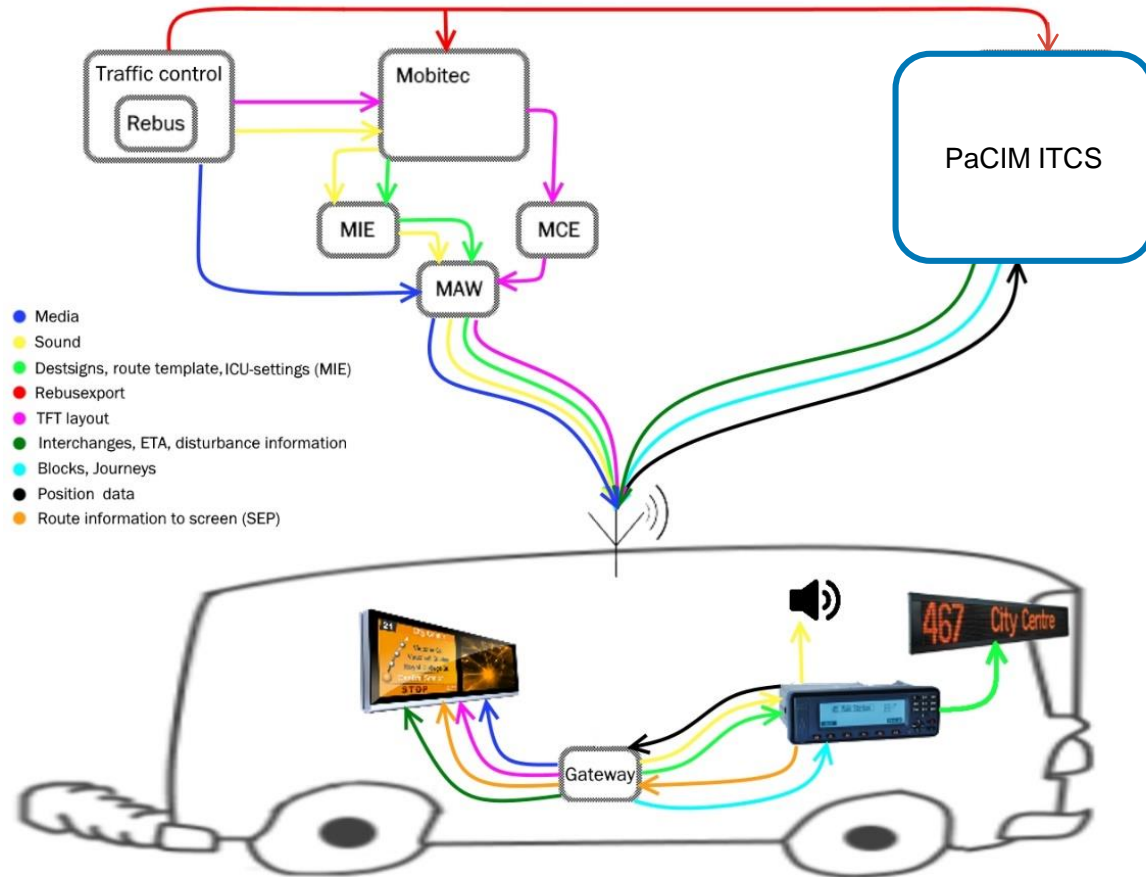

Real Time Information for Destination Signs

Purpose:

Providing route information on destination sign and real time ETA for the destination

Advantage:

Before embarking the journey customer can have real time ETA for their destination

Operator can enhance the use of their existing digital destination signs



Real Time Information for Destination Signs

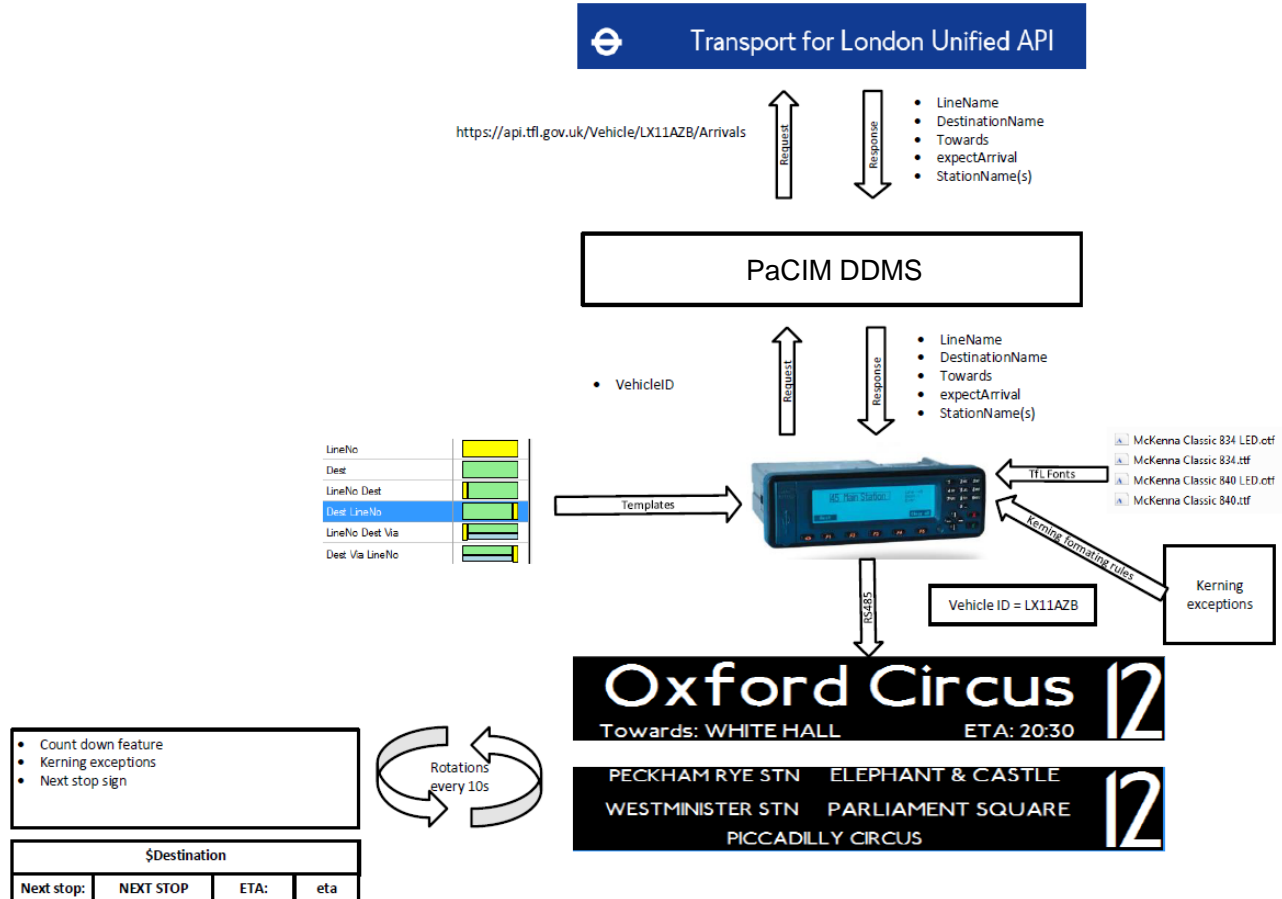

THANK YOU!

